

DO NOT SCALE

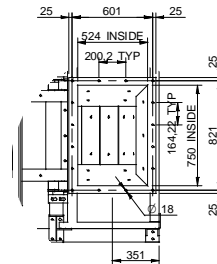

DETAIL A  
 1:20

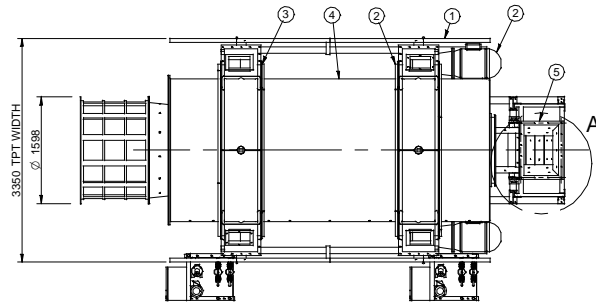
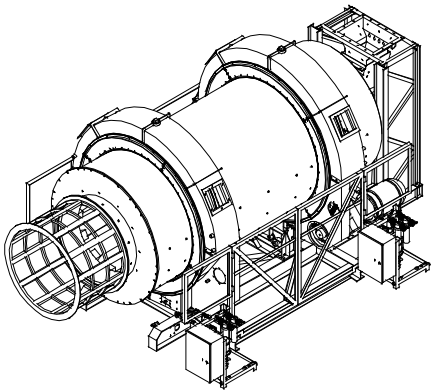
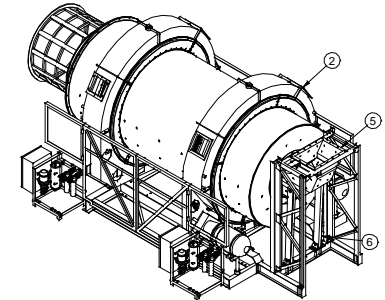

1:50

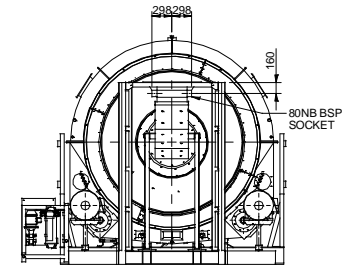
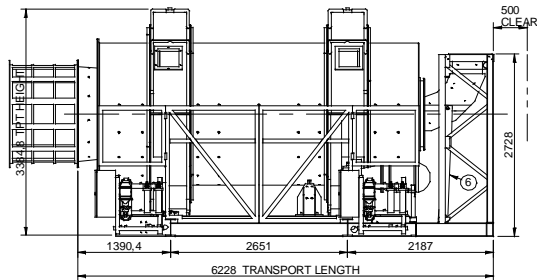
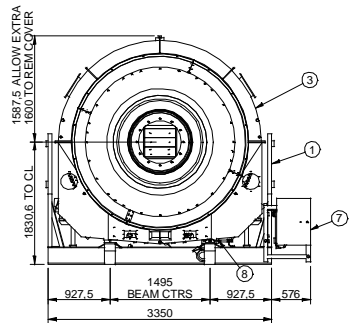

Item Number	Document Number	Title	Quantity	Mass
1	05-0033-5024	BASE FRAME ASSEMBLY	1	1973.2 kg
2	05-0033-4052	DRIVE ASSEMBLY	1	2746.0 kg
3	05-0033-4081	BEARING ASSEMBLY	1	2971.3 kg
4	05-0033-4002	DRUM ASSEMBLY	1	13079.7 kg
5	05-0033-5018	INLET ASSEMBLY	1	479.1 kg
6	05-0033-5019	PIVOT ARM	1	82.4 kg
7	05-0033-5092	LUBE SYSTEM	2	343.1 kg
8	05-0033-5079	MOUNTING	2	18.2 kg
9*	05-0033-5095	LOCATING BRACKET	2	2.4 kg
10*	05-0033-5096	LOCATING BRACKET	2	1.4 kg
11*	07-0078-4110	TROMMEL	1	0.0 kg

REFERENCE	DESCRIPTION	NO.	DATE	CHECK	TOLERANCES	DRAWN	DT	MATERIAL	MECHPROTECH (PTY) LTD. Mechanical Product and Technology Development for Industry	2.1M DIAMETER X 4.8 M LONG SCRUBBER CW 75 KW DRIVE AND DISCHARGE TROMMEL	SCALE: 1:40	DRG NO: A1-07-0078-4012	REV: 0	SHEET 1 OF 1
					ABOVE	DT	2007/12/17							
					0.5	SE								
					3									
					6									
					30									
					120									
					315									
					1000									
					2000									
					2000									